

## Contents

|   |          |
|---|----------|
| <b>Accessibility Guidelines for Recreation Facilities . . .</b>             | <b>1</b> |
| Introduction . . . . .  | 1        |
| <b>Swimming Pools and Spas . . . . .</b>                                    | <b>5</b> |
| Accessible Routes . . . . .   | 6        |
| Types of Facilities and Required Means of Entry into<br>the Water . . . . . | 7        |
| Types of Accessible Means of Entry into the Water . . .                     | 9        |
| Pool Lifts . . . . .  | 9        |
| Sloped Entries . . . . .  | 12       |
| Transfer Walls . . . . .  | 14       |
| Transfer Systems . . . . .  | 16       |
| Accessible Pool Stairs . . . . .  | 18       |
| Water Play Components . . . . .   | 19       |
| Other Accessible Elements . . . . .   | 19       |
| More Information . . . . .  | 20       |

This information has been developed and reviewed in accordance with the Access Board's information quality guidelines ([www.access-board.gov/infoquality.htm](http://www.access-board.gov/infoquality.htm)).

## Accessibility Guidelines for Recreation Facilities

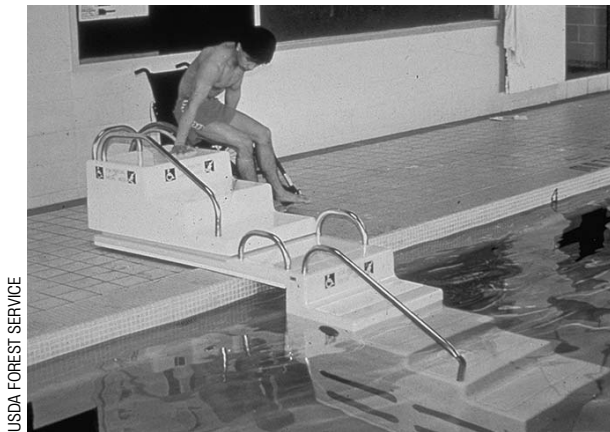

USDA FOREST SERVICE

TRANSFER SYSTEM

### Introduction

The Americans with Disabilities Act (ADA) is a comprehensive civil rights law that prohibits discrimination on the basis of disability. The ADA requires that newly constructed and altered state and local government facilities, places of public accommodation, and commercial facilities be readily accessible to, and usable by, individuals with disabilities. The

ADA Accessibility Guidelines (ADAAG) is the standard applied to buildings and facilities. Recreational facilities, including swimming pools, wading pools, and spas, are among the facilities required to comply with the ADA.

The Access Board issued accessibility guidelines for newly constructed and altered recreation facilities in 2002. The recreation facility guidelines are a supplement to ADAAG. As a supplement, they must be used in conjunction with ADAAG. References to ADAAG are mentioned throughout this summary. Copies of ADAAG and the recreation facility accessibility guidelines can be obtained through the Board's website at [www.access-board.gov](http://www.access-board.gov) or by calling 1-800-872-2253 or 1-800-993-2822 (TTY).

Once these guidelines are adopted by the Department of Justice (DOJ), all newly designed, constructed and altered recreation facilities covered by the ADA will be required to comply.

The recreation facility guidelines cover the following facilities and elements:

- Amusement rides
- Boating facilities
- Fishing piers and platforms
- Miniature golf courses
- Golf courses
- Exercise equipment
- Bowling lanes
- Shooting facilities
- Swimming pools, wading pools, and spas

This guide is intended to help designers and operators in using the accessibility guidelines for swimming pools, wading pools, and spas. These guidelines establish minimum accessibility requirements for newly designed or newly constructed and altered swimming pools, wading pools, and spas. This guide is not a collection of swimming pool or spa designs. Rather, it provides specifications for elements within a swimming pool or spa to create a general level of usability for individuals with disabilities. Emphasis is placed on ensuring that



individuals with disabilities are generally able to access swimming pools and spas and use a variety of elements. Designers and operators are encouraged to exceed the guidelines where possible to provide increased accessibility and opportunities. Incorporating accessibility into the design of a swimming pool or spa should begin early in the planning process with careful consideration to the accessible routes and means of entry into the water.

The recreation facility guidelines were developed with significant public participation. In 1993, the Access Board established an advisory committee of 27 members to recommend accessibility guidelines for recreation facilities. The Recreation Access Advisory Committee represented the following groups and associations:

- American Ski Federation
- American Society for Testing and Materials (Public Playground Safety Committee)
- American Society of Landscape Architects
- Beneficial Designs
- City and County of San Francisco, California, Department of Public Works
- Disabled American Veterans
- Environmental Access
- Golf Course Superintendents Association of America
- Hawaii Disability and Communication Access Board
- International Association of Amusement Parks and Attractions
- Katherine McGuinness and Associates



- Lehman, Smith, and Wiseman Associates
- Michigan Department of Natural Resources
- National Council on Independent Living
- National Park Service
- National Recreation and Park Association
- New Jersey Department of Community Affairs
- Outdoor Amusement Business Association
- Paralyzed Veterans of America
- Professional Golfer's Association
- Self Help for Hard of Hearing People
- States Organization for Boating Access
- Universal Studios
- U.S. Army Corps of Engineers
- U.S. Forest Service
- Y.M.C.A. of the U.S.A.
- Walt Disney Imagineering

The public was given an opportunity to comment on the recommended accessibility guidelines, and the Access Board made changes to the recommended guidelines based on the public comments. A notice of proposed rulemaking (NPRM) was published in the Federal Register in July 1999, followed by a five-month public comment period. Further input from the public was sought in July 2000 when the Access Board published a draft final rule soliciting comment. A final rule was published in September 2002.

*"Whenever a door is closed to anyone because of a disability, we must work to open it... Whenever any barrier stands between you and the full rights and dignity of citizenship, we must work to remove it, in the name of simple decency and justice. The promise of the ADA...has enabled people with disabilities to enjoy much greater access to a wide range of affordable travel, recreational opportunities and life-enriching services."*

*President George W. Bush, New Freedom Initiative, February 1, 2001*

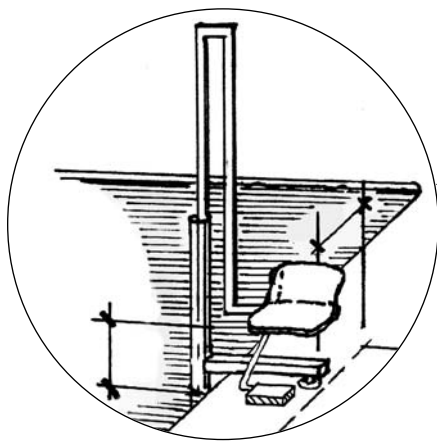

POOL LIFT

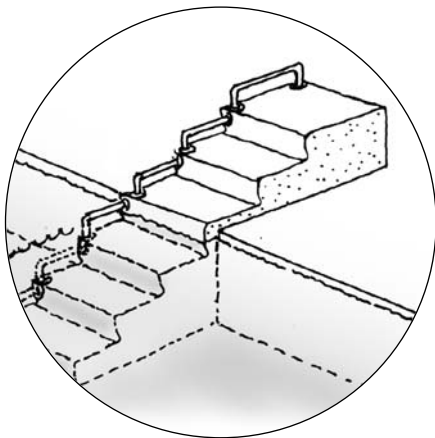

TRANSFER SYSTEM

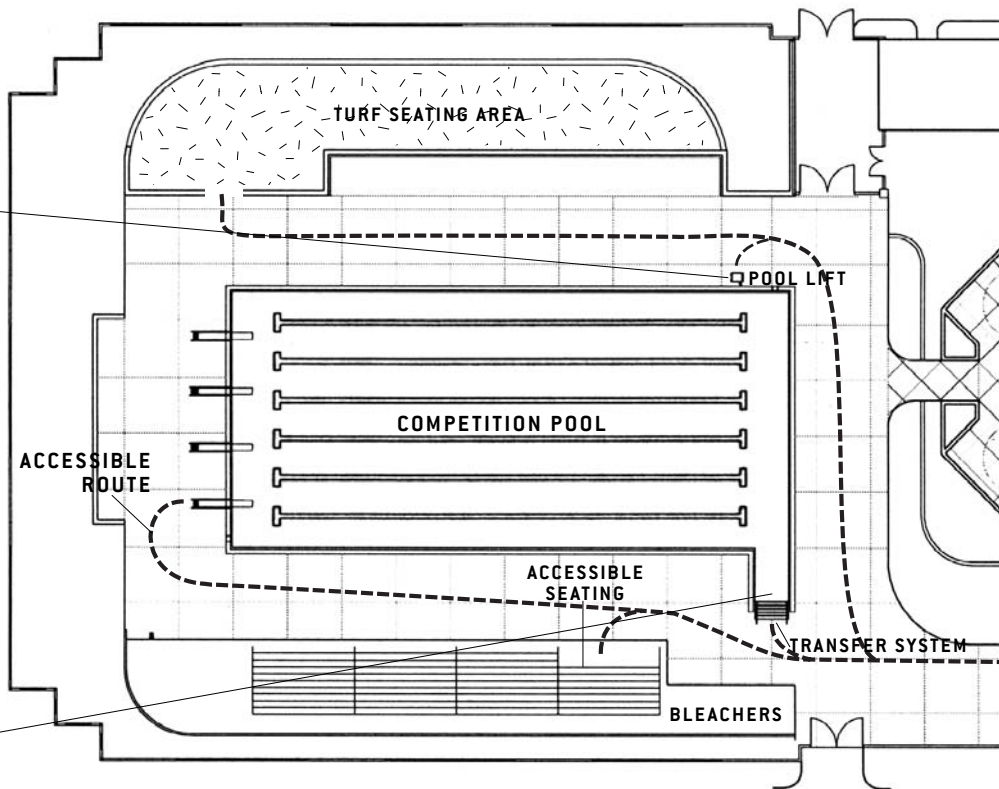

**ACCESSIBLE ROUTE CONNECTING ELEMENTS WITHIN  
A MULTI-USE SWIMMING POOL FACILITY**

## Swimming Pools and Spas

The guidelines described in this guide focus on newly designed or newly constructed and altered swimming pools, wading pools, aquatic recreation facilities, and spas. Other provisions contained in ADAAG address elements commonly found at a swimming facility, such as accessible vehicle parking spaces, exterior accessible routes, and toilet and bathing

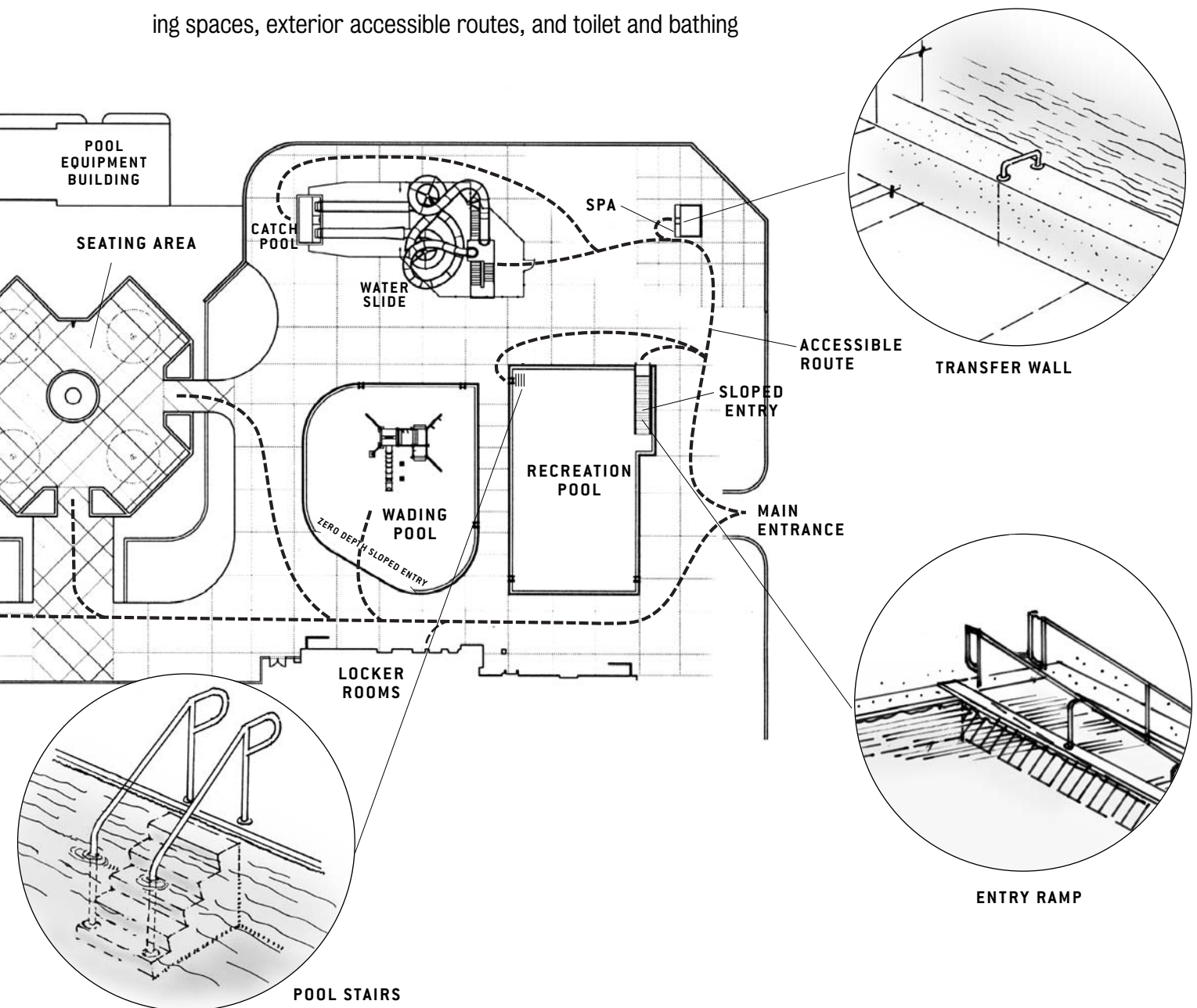

| PERMITTED MEANS OF POOL ACCESS   |              |      |                |                  |        |
|--|--------------|------|----------------|------------------|--------|
| POOL TYPE  | SLOPED ENTRY | LIFT | TRANSFER WALLS | TRANSFER SYSTEMS | STAIRS |
| Swimming (less than 300 linear feet of pool wall)                                      | ✓            | ✓    |                |                  |        |
| Swimming (300 or more linear feet of pool wall)<br>—two means of entry required        | ✓*           | ✓*   | ✓              | ✓                | ✓      |
| Wave action, leisure river, and other pools<br>where user entry is limited to one area | ✓            | ✓    |                | ✓                |        |
| Wading pools   | ✓            |      |                |                  |        |
| Spas   |              | ✓    | ✓              | ✓                |        |

\*Primary means must be by sloped entry or lift, secondary means can be any of the permitted types.

facilities. ADAAG addresses only the built environment (structures and grounds); the guidelines do not address operational issues. Questions regarding operational issues should be directed to the Department of Justice, 1-800-514-0301 or 1-800-514-0383 (TTY).

### **Accessible Routes**

Accessible routes are continuous, unobstructed paths connecting all accessible elements and spaces of a building or facility. Accessible route requirements in ADAAG address width (minimum of 36 inches), passing space, head room, surface, slope (maximum of 1:12 or 8.33%), changes in level, doors, egress, and areas of rescue assistance, unless modified by specific provisions outlined in this guide. An accessible route is required to provide access to the swimming areas and all the supporting amenities. An accessible route is not required to serve raised diving boards, platforms, or water slides.

## Types of Facilities and Required Means of Entry into the Water

### Swimming Pools

Large pools must have a minimum of two accessible means of entry. A large pool is defined as any pool with over 300 linear feet of pool wall. Pool walls at diving areas and in areas where swimmers cannot enter because of landscaping or adjacent structures are still counted as part of the pool's total linear feet.

The primary means of entry must be either a sloped entry into the water or a pool lift that is capable of being independently operated by a person with a disability. The secondary means of entry could be a pool lift, sloped entry, transfer wall, transfer system, or pool stairs. It is recommended that where two means of entry are provided, they be different types and be situated on different pool walls.

Pools with less than 300 linear feet of pool wall are only required to provide one accessible means of entry, which must be either a pool lift or sloped entry.

### Aquatic Recreation Facilities

Wave action pools, leisure rivers, sand bottom pools, and other pools where access to the water is limited to one area and where everyone gets in and out at the same place, must provide at least one accessible means of entry, no matter how many linear feet of pool wall is provided. The accessible

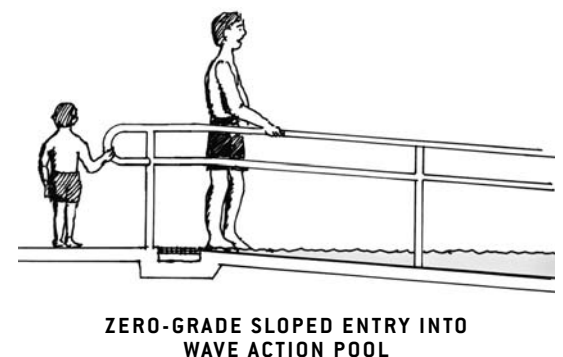
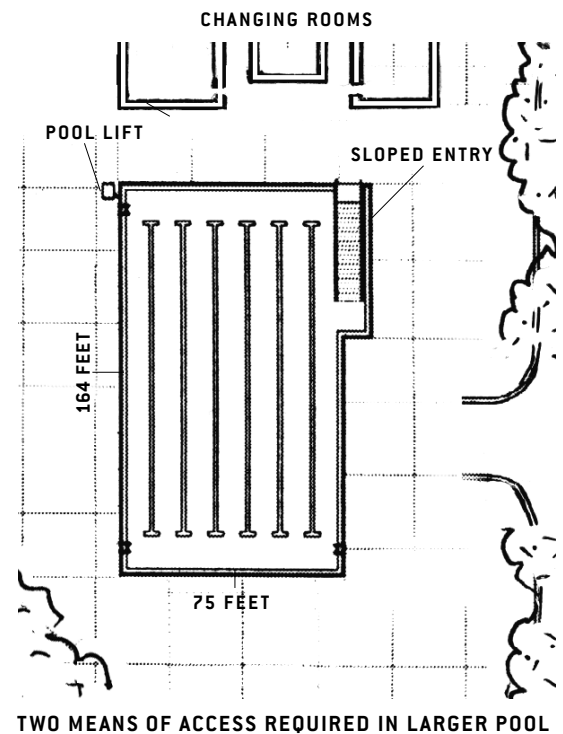

NATIONAL CENTER ON ACCESSIBILITY



**INDIVIDUAL ENTERING  
A WAVE ACTION POOL**

means of entry can be either a pool lift, sloped entry, or transfer system.

## Catch Pools

A catch pool is a body of water where water slide flumes drop users into the water. An accessible means of entry or exit is not required into the catch pool. However, an accessible route must connect to the edge of the catch pool.

## Wading Pools

A wading pool is a pool designed for shallow depth and is used for wading. Each wading pool must provide at least one sloped entry into the deepest part. Other forms of entry may be provided as long as a sloped entry is provided. The sloped entries for wading pools are not required to have handrails.

## Spas

Spas must provide at least one accessible means of entry, which can be a pool lift, transfer wall, or transfer system. If spas are provided in a cluster, 5 percent of the total—or at least one spa—must be accessible. If there is more than one cluster, one spa or 5 percent per cluster must be accessible.

Footrests are not required on pool lifts provided at spas. However, footrests or retractable leg supports are encouraged, especially on lifts used in larger spas, where the water depth is 34 inches or more and there is sufficient space.

USDA FOREST SERVICE



**LIFT ON A SPA**

## Types of Accessible Means of Entry into the Water

### Pool Lifts

Pool lifts must be located where the water level is not deeper than 48 inches. This provides the opportunity for someone to provide assistance from a standing position in the water if desired. If multiple pool lift locations are provided, only one must be where the water is less than 48 inches. If the entire pool is deeper than 48 inches, an exception allows operators to use a pool lift in any location as an accessible means of entry.

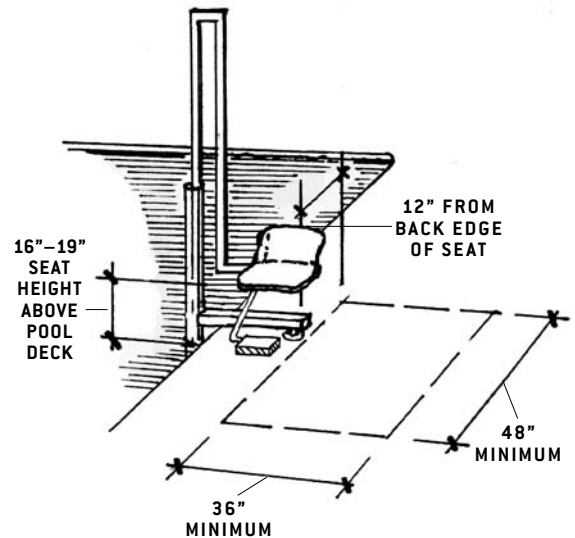

POOL LIFT

### Seats

There are a variety of seats available on pool lifts and these guidelines do not specify the type of material or the type of seat required. However, lift seats must be a minimum of 16 inches wide. In the raised (load) position, the centerline of the seat must be located over the deck, a minimum of 16 inches from the edge of the pool. The deck surface between the centerline of the seat and the pool edge cannot have a slope greater than 1:48.

Although not required, seats with backs will enable a larger number of persons with disabilities to use the lift independently. Pool lift seats made of materials that resist corrosion, that provide a firm base, and that are padded are more usable. Headrests, seat belts, and additional leg support may also enhance accessibility and accommodate a wider variety of people with disabilities.



INDIVIDUAL USING A POOL LIFT

### Clear Deck Space

Clear deck space must be provided to enable a person to get close enough to the pool lift seat to easily transfer from a wheelchair or mobility device. This clear deck space will ensure an unobstructed area for transfers between a mobility device and the seat. The clear deck space must be a minimum of 36 inches wide and extend forward a minimum of 48 inches from a line located 12 inches behind the rear edge of the seat. This space must be located on the side of the seat opposite the water. The slope of the clear deck space must not be greater than 1:48 (2%). This virtually flat area will make the transfer easier and safer, while still allowing water to drain away from the deck.

### Seat Height

The lift must be designed so that the seat will make a stop between a minimum of 16 inches and maximum of 19 inches (measured from the deck to the top of the seat surface, when the seat is in the raised position). Lifts can provide additional stops at various heights to accommodate users of all ages and abilities.

### Footrests and Armrests

Footrests and armrests provide stability for the person using the pool lift. Footrests must be provided on pool lifts, and must move together with the seat. Padding on footrests—large enough to support the whole foot—reduces the chance of injury.

Armrests are not required, however if provided, the armrest opposite the water must be removable or be able to fold clear of the seat when the seat is in the raised (load) position. This clearance is needed for people transferring between the lift and a mobility device.

### Operation

Lifts must be designed and placed so that people can use them without assistance, although assistance can be provided if needed. A person must be able to call the lift when it is in either the deck or water position. It is especially important for someone who is swimming alone to be able to call the lift so she or he won't be stranded in the water for an extended period of time.

The controls and operating mechanisms must be unobstructed when a lift is in use. A person must be able to use the lift with one hand, and the operating controls must not require tight grasping, pinching, or twisting of the wrist. Controls may not require more than five pounds of pressure to operate.

### Submerged Depth

Lifts must be designed so that the seat will submerge to a minimum of 18 inches below the stationary water level. This will ensure buoyancy for the person on the lift and make it easier to enter or exit.

### Lifting Capacity

Lifts must have the capability of supporting a minimum weight of 300 pounds and be capable of sustaining a static load that

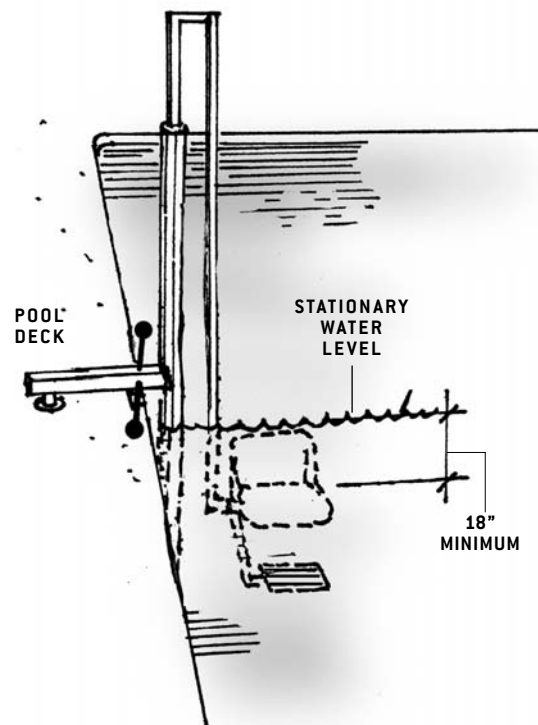

POOL LIFT SUBMERGED DEPTH

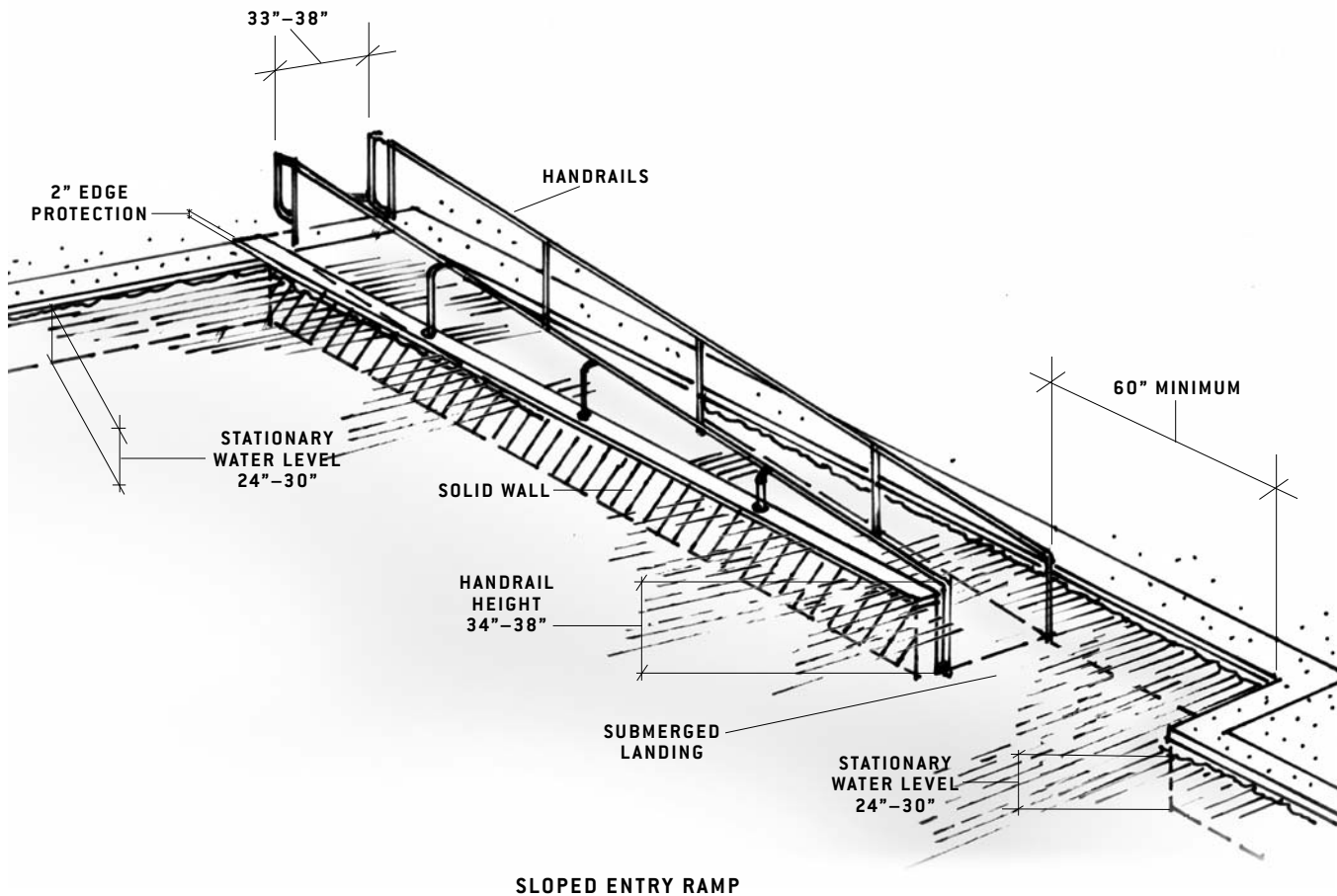

is at least 1.5 times the rated load. Where possible, lifts that can support a greater weight capacity are encouraged.

### Sloped Entries

Sloped entries must comply with ADAAG accessible route provisions (36 inch minimum width, maximum 1:12 or 8.33% slope), except that the surface does not need to be slip resistant. The slope may be designed as zero grade beach or ramp access. With either design, the maximum slope permitted is 1:12 (8.33%).

In most cases, it is not appropriate to submerge personal wheelchairs and mobility devices in water. Some have batteries, motors, and electrical systems that can be damaged or contaminate the pool. Facilities that use sloped entries are encouraged to provide an aquatic wheelchair designed for access into the water. Persons transfer to the aquatic wheelchair and access the water using it, leaving their personal mobility device on the deck. Operators and facility managers may need to consider storage options for personal mobility devices if deck space is limited.

### Submerged Depth

Sloped entries must extend to a depth between 24 inches minimum and 30 inches maximum below the stationary water level. This depth is necessary for individuals using the sloped entry to become buoyant. Where the sloped entry has a running slope greater than 1:20 (5%), a landing at both the top and bottom of the ramp is required. At least one landing must be located between 24 and 30 inches below the stationary water level. Landings must be a minimum of 36 inches in width and 60 inches in length. The sloped entry may be a maximum of 30 feet at 1:12 (8.33%) slope before an intermediate landing is required. Adding a solid wall on the side closest to the water can enhance safety.

### Handrails

Sloped entries must have handrails on both sides regardless of the slope. Handrail extensions are required at the top landing but not at the bottom. The clear width between



INDIVIDUAL USING A SLOPED ENTRY

NATIONAL CENTER ON ACCESSIBILITY

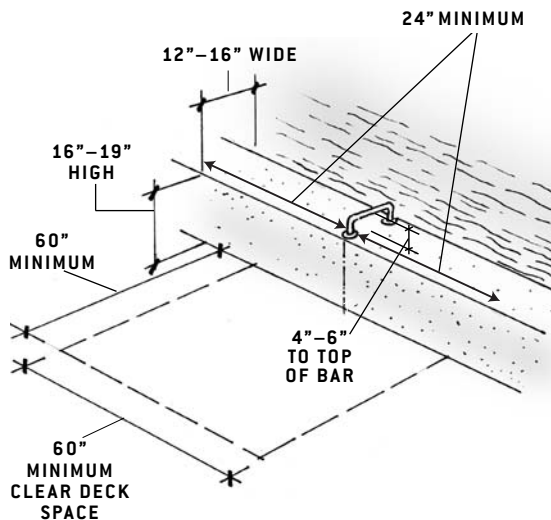

TRANSFER WALL WITH ONE GRAB BAR

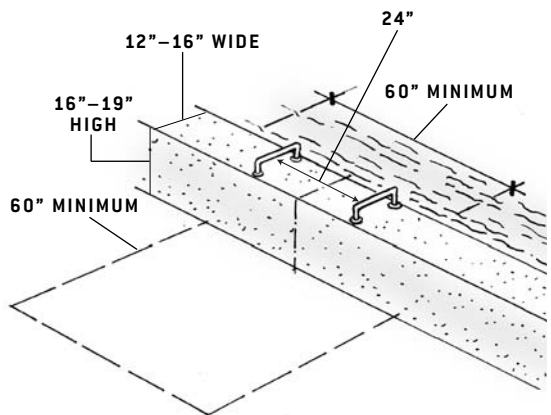

TRANSFER WALL WITH TWO GRAB BARS

handrails must be between 33 and 38 inches. The handrail height must be between 34 and 38 inches to the top of the gripping surface. This provision does not require the handrails to be below the stationary water level, which could be considered an underwater obstruction. No minimum width is required between handrails provided on sloped entries that serve wave action pools, leisure rivers, sand bottom pools, and other pools where people can enter only in one place. Handrails are required to comply with ADAAG provisions (diameter, non-rotating, and height).

### Transfer Walls

A transfer wall is a wall along an accessible route that allows a person to leave a mobility device and transfer onto the wall and then into a pool or spa.

### Grab Bars

Transfer walls must have at least one grab bar. Grab bars must be perpendicular to the pool wall and extend the full width of the wall so a person can use them for support into the water. The top of the gripping surface must be 4 to 6 inches above the wall to provide leverage to the person using the bars. If only one bar is provided, the clearance must be a minimum of 24 inches on each side of the bar. If two bars are provided, the clearance must be a minimum of 24 inches between the bars. The diameter of the grab bars must comply with ADAAG (diameter between 1.25 and 1.5 inches, not abrasive, and non-rotating).

### **Clear Deck Space**

Clear deck space of 60 by 60 inches minimum, with a slope of not more than 1:48, must be provided at the base of a transfer wall. This will allow persons using a wheelchair to turn around and access the wall, depending on the side they can best use to transfer. If there is one grab bar on a transfer wall, the clear deck space must be centered on the one grab bar. That allows enough space for a transfer on either side of the bar. If two bars are provided, the clear deck space must be centered on the 24-inch clearance between the two bars.

### **Height**

The transfer wall height must be 16 inches minimum to 19 inches maximum, measured from the deck.

### **Width and Length**

Transfer walls must be a minimum of 12 inches wide to a maximum of 16 inches wide. This provides enough space for a person to sit comfortably on the surface of the wall and pivot to access the water. The wall must be a minimum of 60 inches long and must be centered on the clear deck space. Additional length will provide increased space and options for transferring.

### **Surface**

Since people using transfer walls are in bathing suits, their skin may be in contact with the wall. To prevent injuries, the wall surface must have rounded edges and not be sharp.

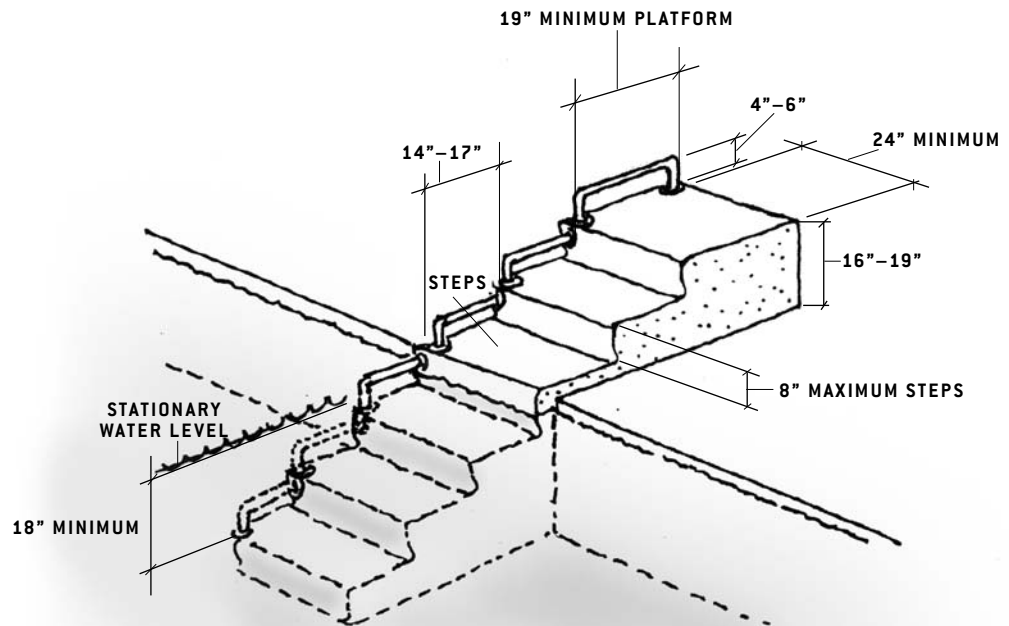

TRANSFER SYSTEM PLATFORM AND STEPS

## Transfer Systems

A transfer system consists of a transfer platform and a series of transfer steps that descend into the water. Users need to transfer from their wheelchair or mobility device to the transfer platform and continue transferring into the water, step by step, bumping their way in or out of the pool.

### Transfer Platform

Each transfer system must have a platform on the deck surface so users can maneuver on and off the system from their mobility device or wheelchair. Platforms must be a minimum of 19 inches deep by 24 inches wide. That provides

enough room for a person transferring to maintain balance and provides enough space to maneuver on top of it.

### Platform Height

Transfer platforms must be between 16 and 19 inches high, measured from the deck.

### Clear Deck Space

The base of the transfer platform must have a clear deck space adjacent to it that is 60 by 60 inches minimum, with a slope not steeper than 1:48 so a person using a wheelchair can turn around and maneuver into transfer position. The space must be centered along the 24-inch minimum unobstructed side of the transfer platform. A level, unobstructed space will help a person transferring from a mobility device.

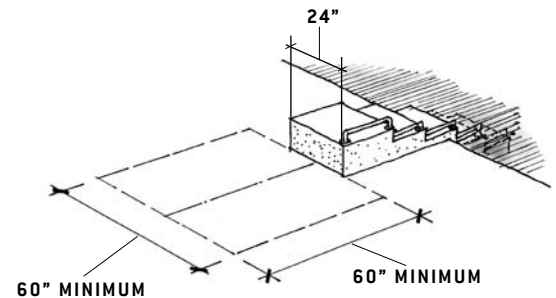

CLEAR DECK SPACE LOCATED AT A TRANSFER SYSTEM

### Transfer Steps

The maximum height of transfer steps is 8 inches, although shorter heights are recommended. Each transfer step must have a tread depth of 14 inches minimum to 17 inches maximum and a minimum tread width of 24 inches. The steps must extend into the water a minimum of 18 inches below the stationary water level.

### Surface

The surface of the transfer platform and steps must not be sharp and must have rounded edges to prevent injuries.

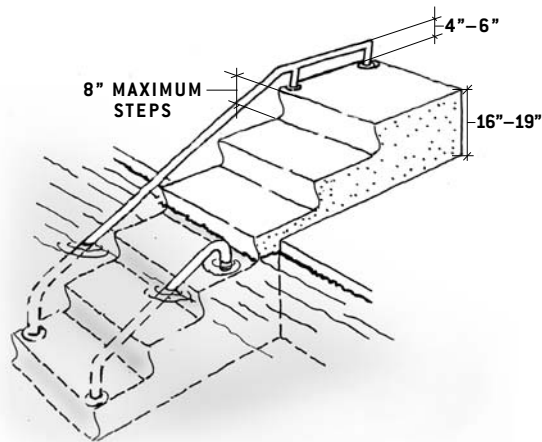

CONTINUOUS GRAB BAR AT TRANSFER SYSTEM

### Grab Bars

A grab bar must be provided on at least one side of each step and on the transfer platform (shown on page 16), or as a continuous grab bar serving each step and the platform (shown at left). The bar must not obstruct transfer onto the platform. If a grab bar is provided on each step, the top of the gripping surface must be 4 inches minimum to 6 inches maximum above each step. If a continuous bar is provided, the top of the gripping surface must be 4 inches minimum to 6 inches maximum above each step nosing. Grab bars on transfer systems must comply with ADAAG (diameter between 1.25 and 1.5 inches, not abrasive, and non-rotating).

### Accessible Pool Stairs

Accessible pool stairs are designed to provide assistance with balance and support from a standing position when moving from the pool deck into the water and out. ADAAG provisions for stairs include the requirement that all steps have uniform riser heights and uniform tread widths of not less than 11 inches, measured from riser to riser. Additionally, open risers are not permitted. Other stairs or steps provided in the pool are not required to meet these guidelines.

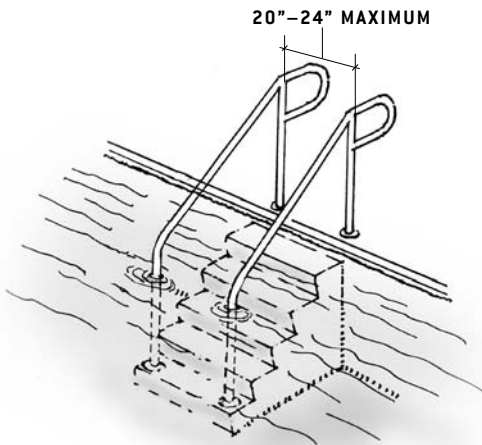

POOL STAIRS

### Handrails

Pool stairs must have handrails with a minimum width between the rails of 20 inches and a maximum of 24 inches. The 20- to 24-inch width for the accessible pool stairs is intended to provide support for individuals with disabilities

who are ambulatory. Handrail extensions are required on the top landing of the stairs but are not required at the bottom landing. Handrails on pool stairs must comply with ADAAG provisions. The top of the handrail gripping surface must be a minimum of 34 inches and a maximum of 38 inches above the stair nosing. If handrails are mounted on walls, the clear space between the handrail and wall must be 1.5 inches.

### Water Play Components

If water play components are provided, they must comply with the Access Board's Play Area Guidelines and accessible route provisions.

If the surface of the accessible route, clear floor or ground spaces, and turning spaces that connect play components are submerged, the accessible route does not have to comply with the requirements for cross slope, running slope, and surface conditions.

Transfer systems may be used instead of ramps to connect elevated water play components.

### Other Accessible Elements

If swimming pools are part of a multi-use facility, designers and operators must also comply with ADAAG and all applicable requirements for recreation facilities. These include, but are not limited to:

- Dressing, fitting, and locker rooms



WATER PLAY STRUCTURE

AQUATIC DESIGN GROUP



USDA FOREST SERVICE

INDIVIDUAL USING A POOL LIFT

- Exercise equipment and machines
- Areas of sports activities (court sports, sports fields, etc.)
- Play areas
- Saunas and steam rooms

### More Information

You can obtain copies of the recreation facility guidelines, which include swimming pools, wading pools, and spas, and further technical assistance from the U.S. Access Board at **[www.access-board.gov](http://www.access-board.gov)**, **1-800-872-2253**, or **1-800-993-2822 (TTY)**.