



## U.S. ACCESS BOARD TECHNICAL GUIDE

# Using the ADA Standards



The design standards issued under the Americans with Disabilities Act (ADA) by the Department of Justice and the Department of Transportation are used to ensure access to the built environment for people with disabilities. The [ADA Standards](#) apply nationwide, in addition to any applicable state or local codes, where facilities are newly built or altered. Most facilities in the public and private sectors are covered by the ADA.

## Facilities Covered by the ADA

### State and Local Government Facilities

Units of government at the state, county, and local levels are subject to the ADA and must comply with the ADA Standards in new construction and alterations. All types of public facilities are covered, including schools, hospitals, public housing, courthouses, and prisons. Federal facilities are not covered by the ADA, but by an earlier law, the Architectural Barriers Act (ABA) and must meet separate, though very similar, [standards](#).



### Places of Public Accommodation and Commercial Facilities

In the private sector, the ADA Standards apply to places of public accommodation and commercial facilities. Places of public accommodation are facilities that affect commerce and that fall within twelve categories listed in the statute, including stores and shops, restaurants and bars, sales or rental establishments, service establishments, theaters, places of lodging, recreation facilities, assembly areas, private museums, places of education, and others. Nearly all types of private businesses that serve the public are included in the twelve categories, regardless of size. Commercial facilities include office buildings, factories, warehouses, manufacturing plants, and other facilities whose operations affect commerce.

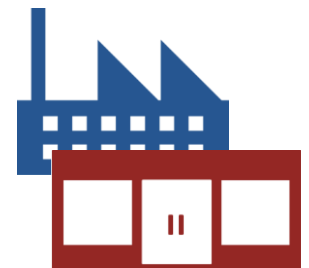

### Transportation Facilities

Bus stops and stations, rail stations, and other transportation facilities are required to be accessible by the ADA. The ADA also establishes standards for transportation vehicles, including buses, vans, and rail cars (which are not discussed in this guide).



### Exemptions (Religious Entities and Private Clubs)

The ADA does not apply to religious organizations and private clubs, entities which historically have been exempt from federal civil rights laws. Places of worship and other facilities controlled by a religious organization, such as a school or day care center, are not subject to the ADA Standards. Private clubs may be similarly exempt depending on their exclusiveness, operations, and other factors. Facilities not subject to the ADA Standards may still be subject to state or local access codes.

## ADA Coverage of Housing

Although private residential housing is not covered by the ADA, government-owned or operated housing and certain privately owned facilities that provide housing are subject to the ADA and its accessibility requirements. Government owned or operated facilities may include public housing, student and faculty housing, employee housing, nursing homes, temporary housing provided in emergencies, and social service facilities, such as homeless shelters and halfway houses.

In the private sector, the ADA's coverage of housing is limited to places of public accommodation, such as social service establishments and housing provided on or behalf a place of education. The ADA does not apply to individually owned or leased housing in the private sector not used as a public accommodation, including single family homes, condominiums, or apartments. (Many types of multi-family housing in the private and public sectors are subject to the design requirements of the Fair Housing Act.) Places of public accommodation located in residential buildings, such as rental and sales offices, commercial spaces, and hotel accommodations, are covered by the ADA Standards.



*Information on the Fair Housing Act is available from the Department of Housing and Urban Development at [www.hud.gov](http://www.hud.gov) or [www.fairhousingfirst.org](http://www.fairhousingfirst.org), (888) 341-7781 (V/TTY).*

## ADA Regulations

Regulations issued by DOJ and DOT to implement the ADA provide important information and instructions on using the ADA Standards. The regulations define the types of facilities covered, set effective dates, and provide additional detail on certain provisions in the standards. They also address existing facilities and topics beyond building design, including access to programs, services, and communication and provision of auxiliary aids and services.

### DOJ's ADA Regulations

DOJ regulations issued under title II of the ADA apply to programs, activities, and services of state and local governments. DOJ's title III regulations apply to public accommodations and commercial facilities. Both regulations contain general nondiscrimination provisions and address access to programs and services, effective communication, auxiliary aids and services, and reasonable modifications of policies, practices, and procedures. Under the title II regulation, state and local



governments must provide program accessibility in existing facilities, and the under the title III regulation public accommodations must remove architectural barriers in existing facilities where it is “readily achievable.” In addition, both regulations specify the accessibility standards applicable to new construction and alterations, and to the provision of program access or barrier removal.



*Title II Regulation for State and Local Governments*  
28 CFR Part 35  
Available at [www.ada.gov](http://www.ada.gov)



*Title III Regulation for Places of Public Accommodation and Commercial Facilities*  
28 CFR Part 36  
Available at [www.ada.gov](http://www.ada.gov)

## DOT's ADA Regulations

DOT's ADA regulations implement the transportation and related provisions of titles II and III of the ADA. They apply to any public entity that provides public transportation or intercity or commuter rail transportation, as well as to any private entity that provides public transportation or that is not primarily engaged in the business of transporting people but operates a demand responsive or fixed route system. They cover both vehicles and facilities and include nondiscrimination requirements associated with the provision of transportation services.



*DOT Regulation for Transportation Services*  
49 CFR Part 37  
Available at [www.fta.dot.gov](http://www.fta.dot.gov)

## ADA Accessibility Standards

Both DOJ's and DOT's ADA Standards are based on minimum accessibility guidelines adopted by the Access Board in 2004, known as the ADA Accessibility Guidelines. As a result, these two sets of standards are very similar for the most part. However, each contains additional requirements that are specific to the facilities covered by the respective agencies.

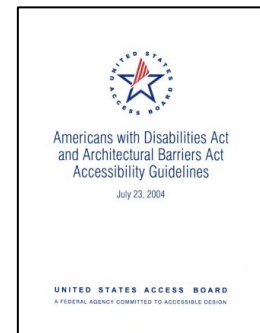

*DOJ's and DOT's ADA Standards are based on the Board's ADA Accessibility Guidelines (2004).*

## DOJ's 2010 ADA Standards for Accessible Design

DOJ's 2010 ADA Standards for Accessible Design became effective March 15, 2012 and apply to all facilities covered by the ADA except public transit facilities. This includes state and local government facilities subject to title II and places of public accommodation and commercial facilities under title III.

As implemented under title II, the 2010 Standards consist of the regulatory provisions in 28 CFR §35.151 and appropriate sections of the Access Board's 2004 ADA Accessibility Guidelines (36 CFR part 1191, appendices B and D).

For title III of the ADA, the 2010 Standards consist of both the regulatory provisions in 28 CFR part 36, subpart D, and appropriate sections of the Access Board's 2004 ADA Accessibility Guidelines (36 CFR part 1191, appendices B and D).

DOJ's 2010 Standards include provisions not included in DOT's standards that supplement or modify requirements related to scoping for:

- assembly areas (§221)
- medical care facilities (§223)
- transient lodging, including housing at places of education (§224)
- detention and correctional facilities (§232)
- social service establishments (§233)
- housing provided by state or local governments for sale to individual owners (§233).

## DOT's ADA Standards (2006)

DOT's ADA Standards apply to facilities used by state and local governments to provide designated public transportation and to commuter and intercity rail stations. The current edition of the standards applies to new construction and alterations undertaken after November 29, 2006. These standards are very similar to DOJ's 2010 Standards but include unique provisions concerning:

- accessible route location (§206.3)
- detectable warnings on curb ramps (§406.8)
- bus boarding and alighting areas (§810.2.2)
- rail station platform (§810.5.3).

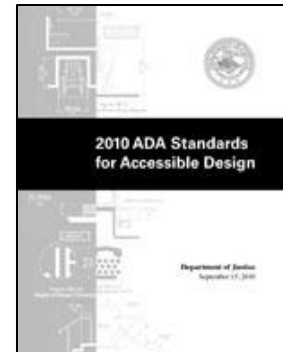

*DOJ's 2010 ADA Standards are available on DOJ's ADA website at [www.ada.gov](http://www.ada.gov).*

## How the ADA Standards are Enforced

DOJ's and DOT's ADA Standards are not a building code, nor are they enforced like one. They constitute design and construction requirements issued under a civil rights law. The ADA's mandates, including the accessibility standards, are enforced through investigations of complaints filed with federal agencies, or through litigation brought by private individuals or the federal government. There is no plan review or permitting process under the ADA. Nor are building departments required or authorized by the ADA to enforce the ADA Standards (some building departments even include a disclaimer on their plan checks indicating that ADA compliance is not part of their approval process). Entities covered by the law ultimately are responsible for ensuring compliance with the ADA Standards in new construction and alterations.

## State and Local Access Codes

Building design and construction, including safety and accessibility, is largely regulated and enforced by states and local jurisdictions. The ADA does not intrude upon the authority these governmental entities have traditionally exercised over the built environment. Most states and many local jurisdictions have laws or ordinances that address access to the built environment. Several states have their own accessibility codes, while others have implemented requirements based on those of the ADA or adopted access provisions contained in model building codes. The ADA Standards apply nationally *in addition to* any applicable state or local access requirements or codes. An occupancy permit issued by a local jurisdiction (or a building inspection) does not ensure ADA compliance. Although local building departments sometimes can waive building code requirements, a local waiver does not affect the entity's obligation to comply with the ADA Standards.

## State or Local Code Certification

The ADA sets up a voluntary process through which a state code can be certified by DOJ as meeting or exceeding the ADA Standards that apply to public accommodations and commercial facilities. Certification facilitates compliance by ensuring that state and local code requirements are consistent with the ADA accessible design requirements. This process, in effect, integrates the requirements for accessible design under the ADA into state or local code enforcement processes. Under a certified code, design errors are more likely to be caught and remedied before construction. Also, having a DOJ-certified code offers rebuttable evidence of compliance with title III of the ADA in response to a legal challenge under the law concerning accessible facility construction. Information on ADA state code certification is available from DOJ and its website at [www.ada.gov/certcode.htm](http://www.ada.gov/certcode.htm). DOT does not certify codes as compliant with its ADA Standards for transportation facilities.



## Model Building Codes and Industry Standards

The Access Board's 2004 ADA Accessibility Guidelines, upon which the current ADA Standards are based, have been harmonized to a significant extent with industry standards and model building codes, including the International Building Code (IBC). The IBC contains application and scoping provisions for accessibility (in chapters 10, 11 and 34) that correspond to those in the ADA guidelines (chapters 1 and 2).

For technical provisions, the IBC references a consensus standard developed through the American National Standards Institute (the ANSI A117.1 standard), which is highly consistent with the technical chapters (3-10) of the ADA guidelines. There are some substantive differences. For example, unlike the ADA guidelines, the ANSI standards require an additional vertical grab bar at water closets, transfer shower stalls, and tubs. Detailed comparisons between the 2004 ADA guidelines and the IBC/ANSI standard are available on the Access Board's website at [www.access-board.gov](http://www.access-board.gov) and the International Code Council's website at [www.iccsafe.org](http://www.iccsafe.org).

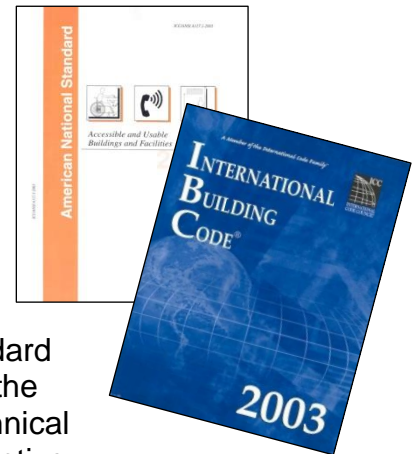

The ADA Standards also reference several industry standards, including the American Society of Mechanical Engineers (ASME) elevator safety code and the National Fire Protection Association (NFPA) 72 Fire Alarm Code. In addition, the ADA Standards reference provisions in the IBC covering accessible means of egress.

## Chapter 1: Application and Administration

### Purpose [§101]

The ADA Standards apply to new construction, alterations, and additions. While the scoping and technical requirements for new construction also apply to alterations and additions, provisions and exceptions specific to alterations or additions are provided throughout the document.

### Furnishings and Equipment

The DOJ and DOT ADA Standards, like most building requirements and codes, apply to those elements that are fixed or built-in. Moveable elements and furnishings are generally not addressed or covered by the ADA Standards. DOJ's ADA regulations include requirements that may impact non-fixed elements, such as providing accessible medical equipment, including examination tables and chairs, to provide persons with disabilities effective access to health services. In addition, placement of non-fixed elements can affect the accessibility of an area by encroaching into accessible routes and clearances.





*Recommendation:* Design spaces so that planned furnishings and moveable elements are accommodated without encroaching into accessible routes and clearances. It is also helpful to consider relevant requirements in the standards when specifying or acquiring moveable furnishings, such as tables, systems furniture, and vending machines to ensure their usability.

Unless specifically permitted, access features required by the ADA Standards must be fixed or built-in even though portable alternatives may be available. This includes requirements for assistive listening systems, visual alarms, shower seats, ramps, and platform lifts. (In removing barriers to existing places of public accommodation, portable solutions may be permitted in some cases where permanent solutions are not readily achievable).

### **Maintenance of Accessible Features**

The ADA Standards address the design, but not the maintenance, of building elements and features. However, it is important that accessible features be properly maintained in working order. DOJ's and DOT's regulations require that features of facilities and equipment required to be accessible be maintained in operable working condition, except for isolated or temporary interruptions in service due to maintenance or repairs.

### **Dimensions for Adults and Children [§102]**

The ADA Standards provide technical specifications for building elements designed specifically for use by children 12 and younger. These provisions address access for children to:

- drinking fountains (§602)
- water closets and toilet compartments (§604)
- lavatories and sinks (§606) and
- dining and work surfaces (§902).

The ADA Standards also include requirements for play areas (§240 and §1008) and recommendations (advisory notes) with respect to children's reach ranges (§301.1) and ramp handrails used primarily by children (§505.4).

The ADA Standards do not specify where or when elements are to be designed or constructed for use primarily by children. This determination is left to other building requirements or regulations, good practice, client preference, or other factors. The provisions covering elements designed for children's use (other than those addressing play areas)



are structured as exceptions to specifications based on adult dimensions. Once the decision is made to design certain elements based on children's dimensions and to use the exceptions, the alternate specifications provided in the ADA Standards must be followed. The ADA Standards do not require provision of additional accessible elements in order to separately accommodate both children and adults, although doing so may be advisable in mixed use spaces. For example, in some restrooms at facilities such as schools and children's museums, it may be a good idea to provide a wheelchair accessible toilet compartment for use by adults and another for use by children.

## **Equivalent Facilitation [§103]**

The ADA Standards allow alternatives to specified requirements that provide substantially equivalent or greater accessibility and usability as an "equivalent facilitation." The question of whether an alternative solution is "equivalent" involves considerations as to whether it is just as, if not more, effective in terms of accessibility, usability, convenience, and reliability for people with disabilities. For example, the ADA Standards specify permanent or built-in features for independent access. Unless otherwise specified, alternatives involving temporary or portable solutions or requiring assistance from others are not generally deemed equivalent to the required minimum level of access.

The provision of equivalent facilitation is intended to accommodate good faith innovations and technological advances not anticipated by the ADA Standards. It is not to be used as a means to resolve oversights in design or construction. Understanding the rationale for certain specifications is often helpful in determining whether an alternative is equivalent. For example, transfer shower stalls are required to be 36 inches by 36 inches absolute so that grab bars remain within reach from the seat. A wider transfer shower stall would not qualify as "equivalent facilitation" because it would make the grab bars less usable from the seat and less accessible to individuals with disabilities.

DOT's ADA regulations (§37.9) detail the process, procedures and requirements for seeking a determination of equivalent facilitation for a public transportation facility subject to DOT's ADA Standards. No departures from specific provisions of the DOT standards can be made without a determination issued by the Administrator of the relevant operating administration (e.g., the Federal Transit Administration, the Federal Railroad Administration, or the Federal Highway Administration) with the concurrence of the Assistant Secretary for Transportation Policy. Requests for official determinations of equivalent facilitation should be directed to the Federal Transit Administration.

DOJ's ADA regulations do not establish a process for approving or certifying equivalent facilitation alternatives to requirements of DOJ's ADA Standards. In the case of DOJ's ADA Standards, the responsibility for demonstrating equivalent facilitation in the event of a legal challenge or complaint rests with the covered entity. In pursuing equivalent facilitation alternatives under DOJ's ADA regulations, it is good practice to:



- base decisions on sound independent research and reliable data
- involve disability groups and individuals with a variety of disabilities in the process
- document the effort thoroughly, including information and feedback from consulted sources

## Conventions [§104]

Most dimensions in the ADA Standards are specified as a minimum, maximum, or as a range. In a few areas, absolute dimensions are specified.

### Construction and Manufacturing Tolerances

A tolerance is an unintended, but permitted (i.e., “tolerated”), variation from a specified dimension resulting from the process of construction or manufacture. The ADA Standards recognize conventional industry tolerances for dimensions not expressed as a range. This applies to field work, not design work. Tolerances necessary for a particular manufacturing process are also permitted. Information on specific tolerances may be available from industry and trade organizations, code groups and building officials, and published references.

Many dimensions in the ADA Standards are expressed as a range instead of an absolute so that designers can allow some room for minor deviations in construction or manufacturing. Tolerances do not apply to dimensions specified as a range.

### Calculation of Percentages

Some provisions in the ADA Standards specify a minimum number of elements or spaces as a minimum percentage or proportion. Rounding up to the next greater whole number is required where fractions or remainders occur. For example, if the standards require access to at least 5% of an element and a total of 25 are provided, at least 2 must be accessible (rounding up from 1.25).

### Grab Bar Diameter and Clearance

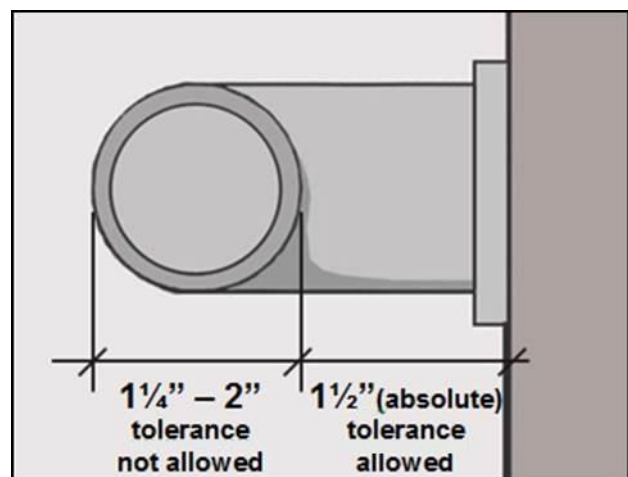

*Construction or manufacturing tolerances are permitted for the required clearance at grab bars since this is an absolute dimension (1½ inch), but they are not permitted for the grab bar diameter because a range is specified (1¼ to 2”).*

In the case of specifications for dimensions or sizes that involve percentages or ratios, rounding down for values less than one half is allowed.



**Recommendation:** Dimensions expressed as a range are intended to accommodate deviations in the field. It is good practice to specify accordingly. For example, for the location of wheelchair accessible water closets (16" – 18" centerline from side walls or partitions), specifying to the midpoint of the range (17") will accommodate any construction variations up to 1" plus or minus. For dimensions not expressed as an absolute ("X maximum" or "Y minimum"), specify in a manner that accommodates the expected tolerance *within* the required dimensions by subtracting the tolerance from the required maximum or adding it to the required minimum.

### Figures in the Standards

Figures in the ADA Standards are provided only for informational purposes to illustrate dimensions and requirements contained in the text. They do not establish enforceable requirements unless specifically stated otherwise.

### Referenced Standards [§105]

The ADA Standards reference industry standards for certain elements, including automated doors (ANSI/BHMA standards), means of egress (IBC), fire alarms (NFPA National Fire Alarm Code), elevators and platform lifts (ASME Safety Code), and play surfaces (ASTM standards).

The specific editions of these documents referenced by the ADA Standards must be followed. Use of a more recent edition of a referenced standard is not recognized until DOJ and DOT update their standards to reference that edition. Compliance with a later edition may be possible under the provision for "equivalent facilitation" if it is comparable to, or provides greater accessibility than, the editions currently referenced by the ADA Standards.

### Definitions [§106]

Many important terms used in the ADA Standards are defined in section 106. DOJ's and DOT's regulations also include definitions that are relevant to use of the ADA Standards. For example, DOJ's regulations define entities covered by the ADA, such as "places of public accommodation," or that are exempt from the ADA, such as "religious entities."

Defined terms in referenced standards govern when those terms are not defined in either the ADA Standards or regulations. Section 106.3 of the ADA Standards provides that terms not specifically defined in section 106.5, in regulations issued by either DOJ or DOT, or in referenced standards, shall be defined by collegiate dictionaries in the sense that the context implies.

## Common Questions



*How are the ADA Standards developed?*

The ADA charges the Access Board with the responsibility of developing guidelines for accessible design that are intended to serve as the basis for mandatory and enforceable ADA Standards adopted by DOJ and DOT. The ADA Standards and the Board's guidelines are developed and adopted using the procedures that apply to the federal rulemaking process. Under this process, agencies publish proposed language in the *Federal Register*, and then provide the public with the opportunity to provide input during a specified comment period. Often, agencies also hold public hearings during the comment period. Prior to publication of the final rule, agencies must review the public comments they have received. They also must assess the costs and benefits of the new guidelines or standards on the public, including their impact on small businesses. The same process must be followed for changes and updates to the guidelines and standards.

*Do the ADA Standards override state or local requirements?*

No, both the ADA Standards and all applicable state and local requirements must be satisfied. Where there is a difference, the standard that provides greater accessibility must be followed.

*If a state or local authority interprets an accessibility requirement differently than how a comparable requirement in the ADA Standards is interpreted under the ADA (or waives that requirement completely), does this have any bearing on ADA compliance?*

No. While state or local authorities may interpret or waive their own state or local accessibility codes as they see fit, those decisions have no effect on the obligation to comply with requirements of the applicable ADA Standards. Covered entities are still required to design, construct or alter their facilities in compliance with the ADA Standards even where comparable requirements in a state or local code are interpreted or applied differently or are waived altogether by the appropriate state or local official.

*Is there an official review and approval process under the ADA for alternatives pursued as an "equivalent facilitation"?*

There is an official review and approval process under the ADA only for transportation facilities (and vehicles) subject to DOT's ADA regulations, which establish a process for determining whether a specific departure from the specific technical and scoping requirements provides equal or greater accessibility.

DOJ does not have a mechanism to certify any specific variation from its 2010 Standards as being "equivalent." Proposed alternative designs, when supported by available data, are not prohibited; but in any ADA title II or title III investigation, compliance review, or lawsuit, the covered entity would bear the burden of proving that any alternative design provides equal or greater access.

*Can later editions of the industry standards or building codes referenced by the ADA Standards be used?*

The specific editions of the industry standards referenced by the ADA Standards are to be followed until DOJ or DOT revises its ADA Standards to reference later editions. Compliance with a later edition of a referenced standard or building code not currently referenced by the ADA Standards may be possible under the provision for "equivalent facilitation" if it is comparable to, or provides greater access than, the referenced editions.

## Further Guidance

Technical assistance and additional guidance on using the ADA Standards is available from the:



**U.S. Access Board**  
 (800) 872-2253 (voice)  
 (800) 993-2822 (TTY)  
[ta@access-board.gov](mailto:ta@access-board.gov)  
[www.access-board.gov](http://www.access-board.gov)



**Department of Justice**  
 (800) 514-0301 (voice)  
 (800) 514-0383 (TTY)  
[www.ada.gov](http://www.ada.gov)



**Federal Transit Administration**  
 (888) 446-4511  
[FTA.ADAAssistance@dot.gov](mailto:FTA.ADAAssistance@dot.gov)  
[www.fta.dot.gov](http://www.fta.dot.gov)



**UNITED STATES ACCESS BOARD**  
*Advancing Full Access and Inclusion for All*  
 1331 F Street, NW ▪ Suite 1000 ▪ Washington, DC 20004-1111  
 (202) 272-0080 (v) ▪ (202) 272-0082 (TTY) ▪ [www.access-board.gov](http://www.access-board.gov)

February 2014